

**Fusion
HRV2**
Mechanical Ventilation with Heat Recovery
User / Homeowner Guide

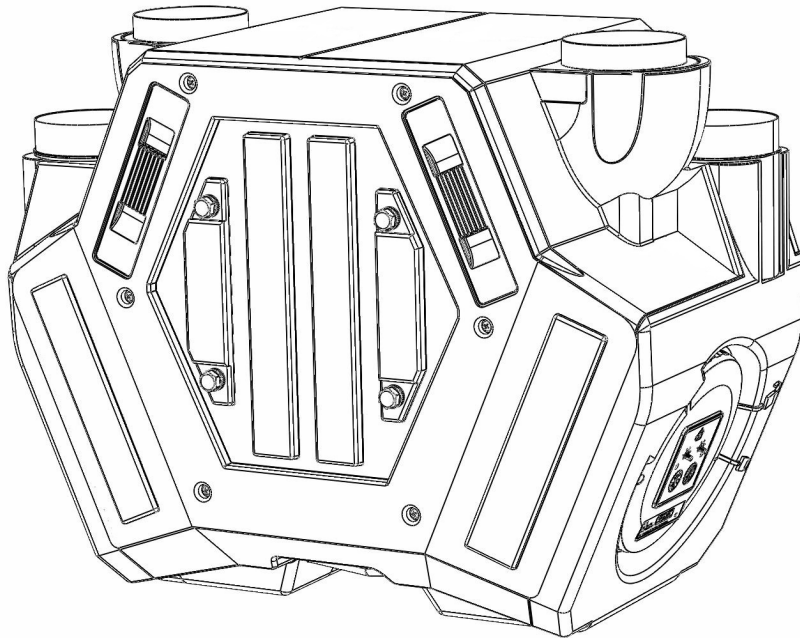

Commissioning and Inspection Record:

Located on page 6 of this guide, should have been completed by the Commissioning Engineer.



Contents

User / Homeowner Information

1. Ventilation In Your Home	Page 2
2. General Overview	Page 3
3. Servicing/Maintenance	Page 3
4. Commissioning & Inspection Record	Page 6
5. Guarantee/Warranty Information	Page 9

1.0 Ventilation In Your Home

Your home has a Heat Recovery Ventilation System installed. This consists of a continuously running supply & extract system with heat recovery that is linked by a network of ducts to extract air on a continual basis from the following areas in residential dwellings –

- Kitchen
- Bathroom
- Utility Room
- WC/Cloakroom
- Ensuite Bath/Shower Room

And supply air continually to –

- Living Room
- Dining Room
- Bedroom
- Study

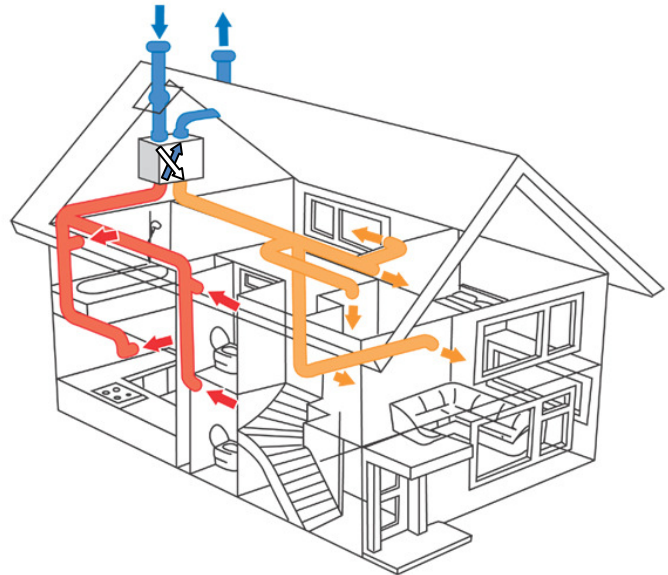
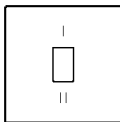

Figure 1

2.0 General Overview

- 2.1.1 The product incorporates a Heat Exchanger that recovers the heat energy from the 'extract air' that would normally be lost with other ventilation systems. It does this using minimal power consumption as the product uses EC low energy motors.
- 2.1.2 Depending on the way your HRV2 unit has been installed, the specific operation may vary. The unit has three speeds available, but may not have been wired to use them all. Options are –
- 1) Trickle Speed: Operating on a continual basis.
 - 2) Medium Speed: Activated manually using our GS1 switch or similar.
 - 3) Boost Speed: Activated manually using our GS1 / GS2 switch or similar.

Note; Not all three speeds may be operational. Medium speed may be disconnected.



GS2 switch markings - Trickle (I) & Boost (II) Operation

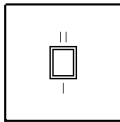

GS1 switch markings - Trickle (Centre), Medium (I) & Boost (II) Operation

Note; Other manufacturers switches may show different markings.

- 2.1.3 To maintain good indoor air quality within the dwelling it is important that the ventilation system remains in operation at all times unless powered down periodically for maintenance/repair.
- 2.1.4 The appliance is not intended for use by young children or infirm persons unless they have been adequately supervised by a responsible person to ensure that they can use the appliance safely. Young children should be supervised to ensure that they do not play with the appliance.
- 2.1.5 **'If the supply cord is damaged, it must be replaced by a special cord/assembly available from the manufacturer or its service agent. The replacement must be carried out by a qualified Electrician in accordance with IEE or local regulations'.**

3.0 Servicing/Maintenance

- 3.1.1 Your HRV2 unit contains self-cleaning backward curved impellers that require no servicing. **The motors have sealed for life bearings, which do not require lubrication.**
- 3.1.2 Periodic cleaning of the ceiling supply & extract valves should be carried out as required, taking care not to adjust the valves set position, as this may cause an unbalanced system, resulting in either under ventilation or unnecessary over ventilation occurring.
- 3.1.3 Periodic inspection and/or cleaning/replacement of filters should be carried out. Frequency greatly depends on geographic location and urban density. The filters trap dirt in the atmosphere and act as protection for both the system and the dwelling. The system's airflow can be reduced if the filters are not cleaned regularly and this can affect overall system performance. For this reason, it is important to clean the filters regularly and to replace them as often as each year.
- 3.1.4 Please contact us on 01903 771021 for replacement filters.
- 3.1.5 **To Clean and Replace Filters**

To Clean Filters: Steps 1 to 8 (Approximately 6 month intervals).

To Replace Filters: Leave out Steps 2 to 7 (Approximately 1 year intervals).

Tip: If the unit has been installed in a new dwelling, it is advisable to clean the filters more frequently than usual because of the increase of dust in the atmosphere.

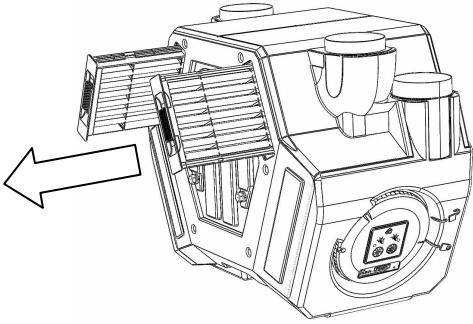

Step 1 – Isolate HRV2 from the Mains Supply and proceed to remove both filters from the unit by the handles.

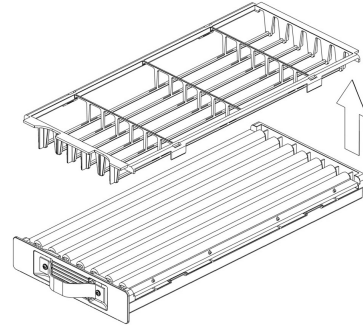

Step 2 - Open the filter cage by unclipping all 4 catches. Two are located on each side of the filter housing

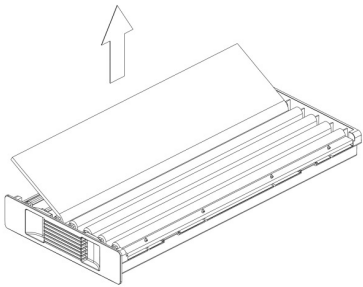

Step 3 - Remove the filter screen from the frame.

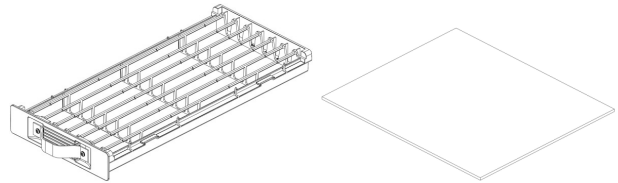

Step 4 – The filter can be vacuumed first and then washed in warm soapy water. Rinse in cold water. Ring out any excess water and towel dry before refitting.

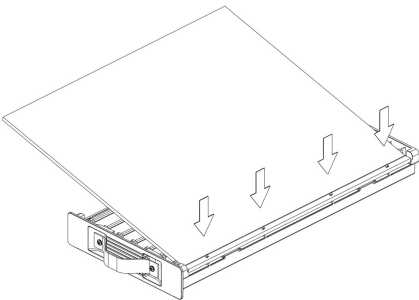

Step 5 – Position the filter material over longest edge and hook the cleaned filter screen onto the frame using the four raised plastic legs to hold in position.

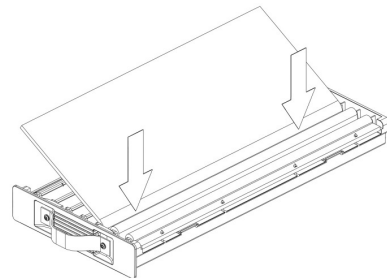

Step 6 – Proceed to gently press the filter material into each channel before moving onto the next.

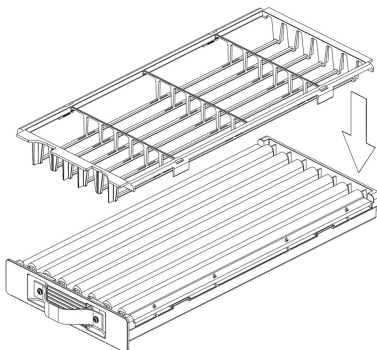

Step 7 – Carefully and slowly close the filter cage ensuring that the clips line up on the frame, and ensuring the filter material sits correctly.

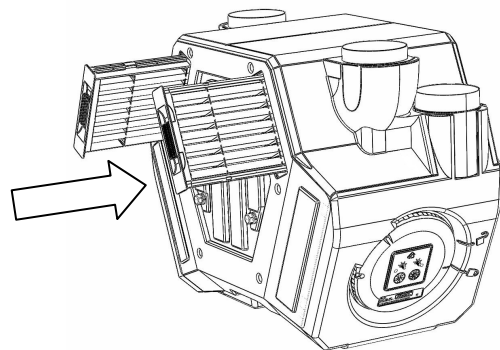

Step 8 – Reinsert filters into the unit. Turn the Mains Supply back on.

3.1.6 To Clean and Replace Heat Exchanger

To Clean Heat Exchanger: Steps 1 to 7 (Approximately 2 year intervals).

To Replace Heat Exchanger: Leave out Step 4 (Approximately 5 year intervals).

Important Note: Do not attempt to wash or clean the heat exchanger with water.

- 1) Isolate your Heat Recovery Unit from the Mains Supply.
- 2) Unscrew the six front panel fixing screws and remove the panel (*See Figure 9*).
- 3) Remove the heat exchanger by gently pulling on the nylon strap, taking care not damage it.
- 4) Clean each face of the heat exchanger carefully with a vacuum cleaner.
- 5) Reinsert the heat exchanger, taking care not to cause damage.
- 6) Reposition the front panel and secure with the six fixing screws.
- 7) Turn the Mains Supply back on.

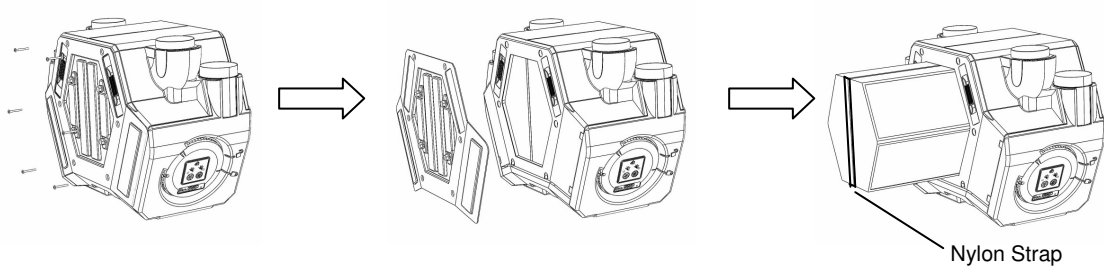

Figure 9

3.1.7 Access for Maintenance

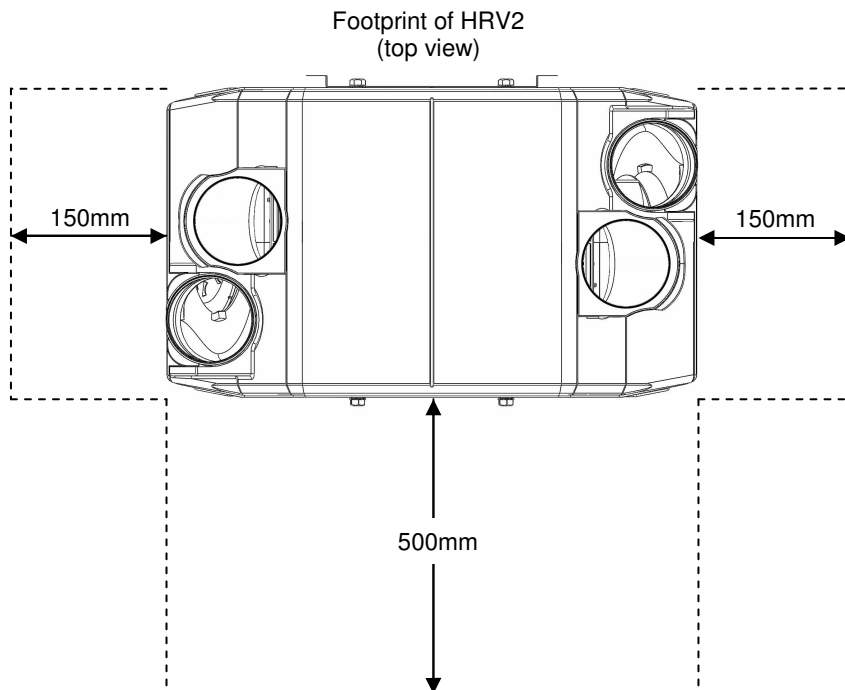

Figure 10

4.0 Commissioning & Inspection Record

4.1.1 This section should be used to record all installation details. The Commissioning Engineer should use the following Parts 1 to 3, to record important information relating to the installation, of which, should be incorporated into the Home Information Pack for the homeowner to keep.

- **Part 1** – System details and declarations
- **Part 2a** – Installation details
- **Part 2b** – Inspection of installation
- **Part 3** – Commissioning details

Part 1 – System details and declarations

1.1 Installation Address Details	
Dwelling Name/Number	
Street	
Locality	
Town	
County	
Post Code	
1.2 Installation Details	
System Classification	System 4 – Balanced supply & extract ventilation with heat recovery
Manufacturer	Greenwood Air Management Limited
Model Number	HRV2
Serial Number (where available)	
Location of HRV2 Unit	
1.3 Installation Engineer's Details	
Engineer's Name	
Company	
Address Line 1	
Address Line 2	
Telephone Number	
Post Code	
1.4 Commissioning Engineer's Details (if different to 1.3)	
Engineer's Name	
Company	
Address Line 1	
Address Line 2	
Telephone Number	
Post Code	

**Note. If a system has been installed that is not defined by System 1 to 4 in Approved Document F, further installation checks and commissioning procedures may be required. Seek particular guidance from the manufacturer for these systems.*

Part 2a – Installation details

2.1 Installation Checklist – General (all Systems)		Tick as appropriate	
Has the system been installed in accordance with manufacturer's requirements?	Yes	No	
Have relevant system installation clauses been followed as details in Tables 1, 3, 5 and 7 as applicable?	Yes	No	
If any deviation from Tables 1, 3, 5 and 7, these should be detailed here			
Description of installed controls (e.g. timer, central control, humidistat, PIR, etc)			
Location of manual/override controls			
2.2 Installation Engineer's Declaration			
Engineer's Signature			
Registration Number (if applicable)			
Date of Inspection			

Part 2b – Inspection of Installation

This section should be completed by the commissioning engineer prior to completing Part 3.

2.3a Visual Inspections – General (all Systems)		
Total floor area of dwelling		m ²
Does the total installed equivalent ventilator area meet the requirements given in Tables 5.2a, 5.2b, or 5.2c in ADF?	Yes	No
Have the correct number and location of terminals been installed that satisfies Table 5.2a in ADF?	Yes	No
Is the installation complete with no obvious defects present?	Yes	No
Do all internal doors have sufficient undercut to allow air transfer between rooms (i.e. 10 mm over and above final floor finish)	Yes	No
Has all protection/packaging been removed such that system is fully functional?	Yes	No
Has the ductwork installation been installed in such manner that air resistance and leakage is kept to a minimum?	Yes	No
Has the entire system been installed such that there is sufficient access for routine maintenance and repair/replacement of components?	Yes	No
2.3a Visual Inspections – General		
Have appropriate air terminal devices been installed to allow system balance?	Yes	No
Has the heat recovery unit and all ductwork been effectively insulated where installed in unheated spaces?	Yes	No
Condensation connection is complete and drains to an appropriate location?	Yes	No
2.3c Other Inspections – General		
Upon initial start up, was any abnormal sound or vibration experiences, or unusual smells detected?	Yes	No

Part 3 – Commissioning details

3.1 Commissioning Equipment

Schedule of air flow measurement equipment used, (model and serial)	Date of last UKAS calibration
1.	
2.	
3.	

3.2 Air Flow Measurements (Extract) – System 4

Room reference (location of terminals)	Measured Air Flow High Rate (l/s)	Design Air Flow High Rate (l/s) Refer to Table 5.1a ADF	Measured Air Flow Low Rate (l/s)	Design Air Flow Low Rate (l/s) Refer to Table 5.1a in ADF
Kitchen				
Bathroom				
En Suite				
Utility				
Other...				
Other...				
Other...				

3.3 Air Flow Measurements (Supply) – System 4

Room reference (location of terminals)	Measured Air Flow High Rate (l/s)	Design Air Flow High Rate (l/s) Refer to Table 5.1b ADF	Measured Air Flow Low Rate (l/s)	Design Air Flow Low Rate (l/s) Refer to Table 5.1b in ADF
Living Room 1				
Living Room 2				
Dining Room				
Bedroom 1				
Bedroom 2				
Bedroom 3				
Bedroom 4				
Bedroom 5				
Study				
Other...				

3.5 Commissioning Engineer's Declaration

Engineer's Signature	
Registration Number (if applicable)	
Date of Commissioning	

5.0 The Guarantee Period

- 5.1.1 This Greenwood product (**HRV2**) is guaranteed for a period of 2 years from the date of purchase of the Product against fault in manufacture. In case of such fault in manufacture apparent during the Guarantee Period, Greenwood may, at its absolute discretion, repair the product, replace the product free of charge or refund the cost of the product AS LONG AS AND ONLY IF:
1. The Product is returned to Greenwood within the Guarantee Period with evidence of purchase date;
 2. The Product has not been misused or handled carelessly or used on an inappropriate voltage supply;
 3. Repairs have not been attempted other than by Greenwood's service staff or authorised dealers; and
 4. In Greenwood's sole discretion, the Product is found to be faulty. If it were not found to be faulty, the Product would be available for collection from the relevant Greenwood's premises within one calendar month and if it was not collected, it would be subsequently delivered by Greenwood and a delivery charge will be made. (the guarantee)
- 5.1.2 This guarantee does not confer any rights other than those expressly set out above and does not cover any claims for consequential loss, damage or any costs incurred in the replacement of the faulty Product.
- 5.1.3 This guarantee is offered as an extra benefit and does not affect your statutory right as a consumer.
- 5.1.4 All information believed correct at time of going to press.
- 5.1.5 All goods are sold according to Greenwood Air Management Ltd's Standard Conditions of Sale which are available on request. All dimensions in millimetres unless otherwise shown.
- 5.1.6 Greenwood Air Management Ltd reserves the right to change specifications and prices without prior notice.
© Copyright Greenwood Air Management Ltd 2006.

Greenwood Air Management Ltd

Greenwood House, Brookside Avenue, Rustington, West Sussex, BN16 3LF.

Main Line Tel: (01903) 771021 Technical Services: (01903) 777135

Main Line Fax: (01903) 782398

Web: www.greenwood.co.uk

Email: info@greenwood.co.uk