

Homeowner quick start guide & commissioning record

Follow these easy steps to make the most of what your **Lossnay** has to offer



Introduction to your new Lossnay ventilation system

(Mechanical Ventilation with Heat Recovery)

This booklet has been created to enable you to understand the ventilation system controls to provide a good quality indoor environment for your home.

If you require more in depth information, please refer to the instruction booklets using the links on **page 15**.

The **Lossnay unit** contains low powered fans that extracts air from bathrooms, kitchens, toilets and utility rooms. It simultaneously supplies a balanced air flow to living spaces such as living rooms and bedrooms.

The unit includes a **heat exchanger** that will warm the incoming fresh air with the energy of the air being extracted. The air paths do not mix with each other and only temperature is exchanged.

Filters keep particles, like dust and pollen from entering inside.

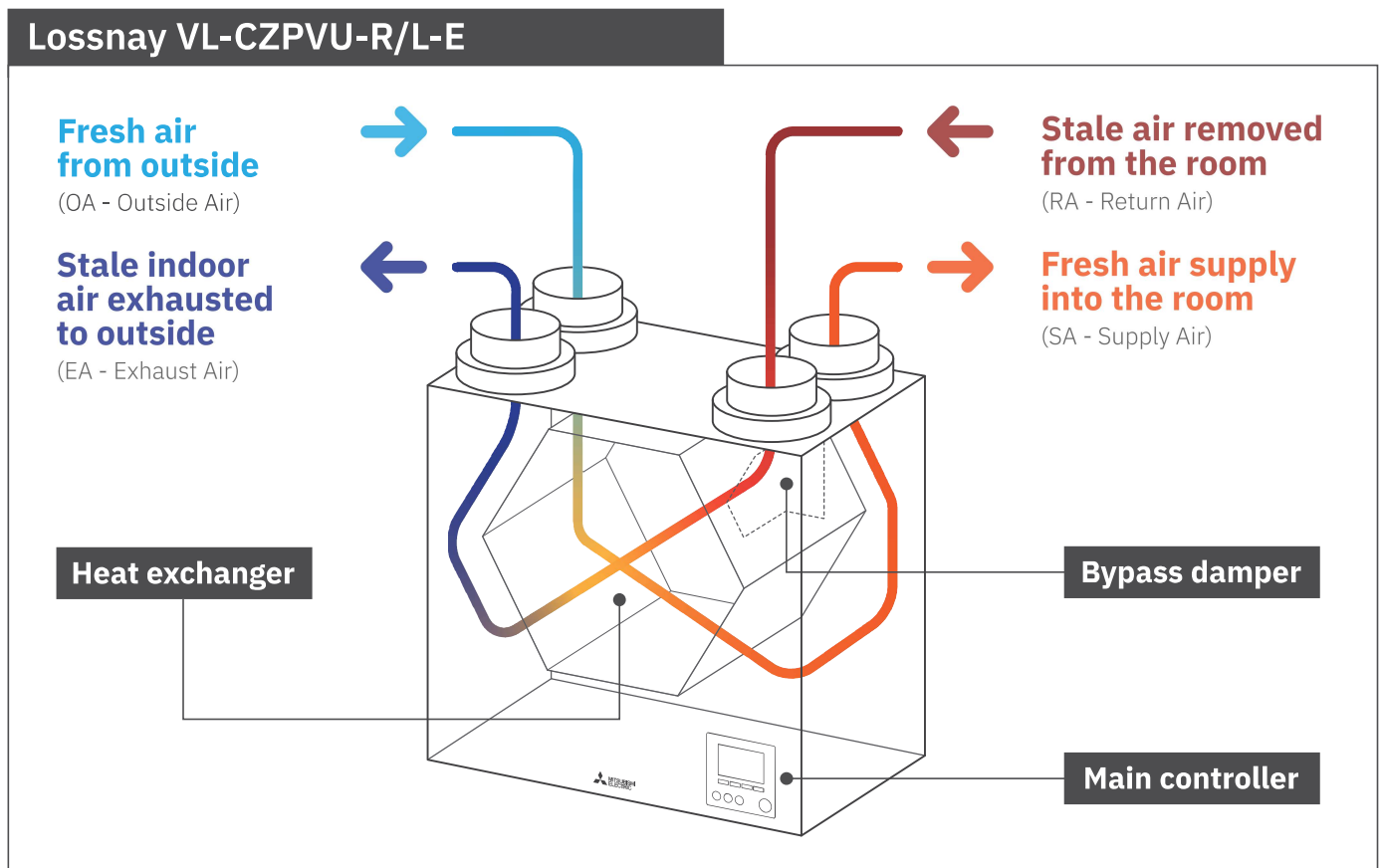

Bypass

The Lossnay unit contains a **bypass damper** that can change the air path of the extracted air so that it bypasses the heat exchanger. In doing so, the supplied fresh air will be the same temperature as the air outside. This can be advantageous during the summer period where you may wish to bring in the colder air from outside to help cool down in the evening.

Putting the unit in auto mode will allow the unit to sense when it is advantageous to do this under the commissioned settings. The commissioner will set the desired indoor temperature during the summer, the minimum outdoor temperature to avoid extreme conditions, and a temperature difference between the two. Details of the commissioned settings should be found in the commissioning log at the back of this document.

Note: this function requires the right indoor/outdoor conditions. It is not the same as active cooling/air conditioning and a cooling effect cannot be guaranteed.

Boost switches

Often, a continuous normal/trickle air flow will maintain the fresh air within your home, and a boost mode will be set up for an event such as showering or cooking when extraction is the most important.

Your unit may be set up to boost automatically, or require you to press a switch nearby. A delay for the boost can be set by the commissioner to stop nuisance tripping, as well as an overrun feature to maintain the boost levels beyond the switch being turned off. Details can be found in the commissioning log at the back of this document. **Avoid leaving the unit in boost to minimise energy usage.**

Air valves/terminals

The air is supplied and extracted from terminals or air valves that may look like this image. They will have been set up and commissioned by a professional engineer to the air flows required in accordance to the building design and building regulations. **Do not attempt to turn or adjust the air valves yourself as you will upset the balance of the system.**



How to operate the system effectively

- The system is set up to require minimal user intervention.
- The system is designed to continuously run 24/7.

Modern building techniques used create homes that are very air tight, meaning air cannot naturally move through the dwelling. This is excellent for energy efficiency and reducing carbon emissions. The Lossnay is a mechanical ventilation system that guarantees your house can breathe appropriately. **Turning off the system can have negative effects on both the dwelling and occupant's health.**

A boost air flow rate may be required during a pollutant generating event such as showering or cooking. The unit can be installed a multitude of ways to receive a boost command. The most common of these will be through a light switch type fitting in the extract rooms. It can also be automatic from turning on the bathroom light or cooker hood, or using humidity sensors.

The installed method should be marked out in the commissioning log book.

Main Remote Controller

To change the settings of your ventilation system please use the main controller located on the front panel.

The following is a quick guide to viewing the main settings.

Should you require more information please refer to the instruction booklet.

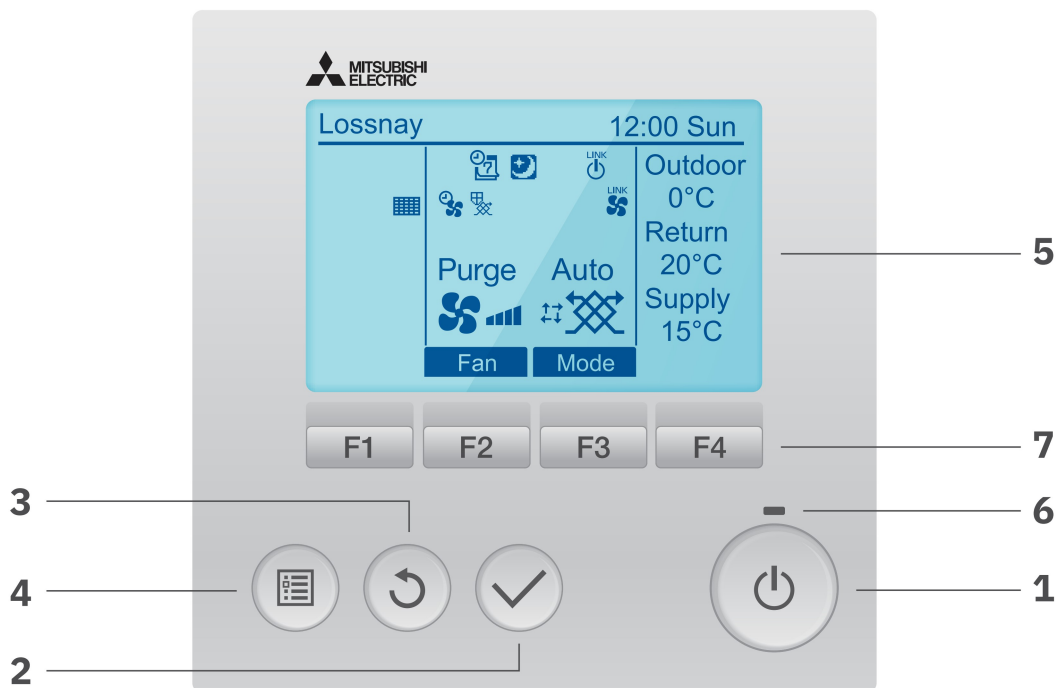







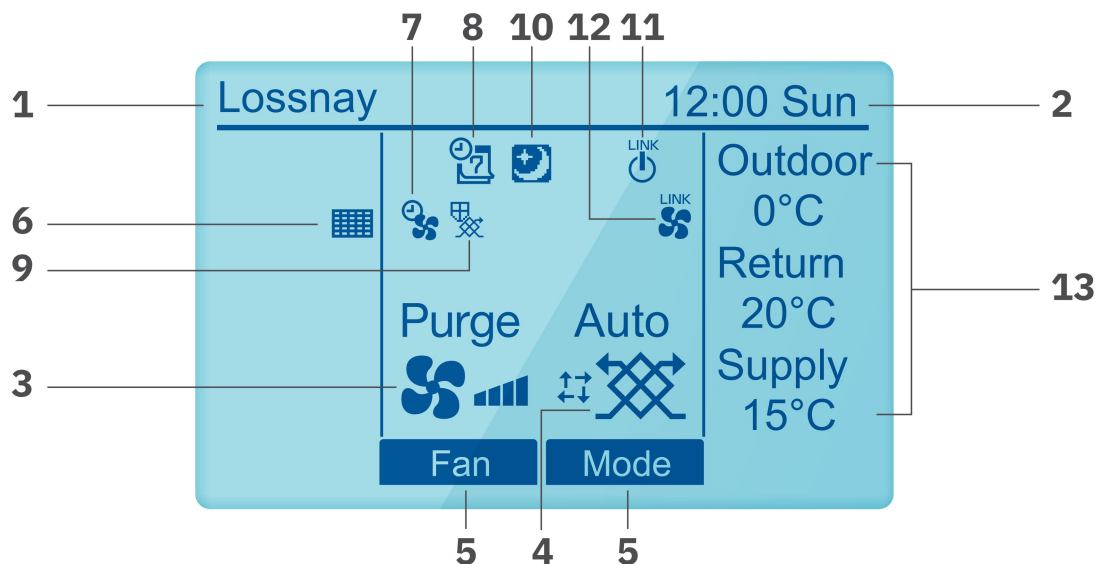

No.	Name	Function
1	ON/OFF button	-
2	SELECT button	-
3	RETURN button	-
4	MENU button	The main menu screen is displayed.
5	Backlit LCD	Press any button to turn on the backlight. You will then be able to operate buttons. The backlight will turn off automatically after a period of time.
6	ON/OFF lamp	This lamp lights up in green while the product is operated. It blinks in green when the product has an error.
7	Function buttons (F1, F2, F3, F4)	Use to select each settings on each screen. The functions of the buttons change depending on the screen.

Main Screen Icons

This display screen highlights all the functions available on your controller.

Please see below an explanation of each icon.



No.	Name	Function
1	Controller Name	Lossnay is always displayed.
2	Clock	Current time and day appear here.
3	Fan speed	Current fan speed setting appears here.
4	Ventilation mode	Current ventilation mode setting appears here.
5	Function button guide	Functions of the corresponding buttons appear here.
6	Filter Sign 	Appears when the filter requires maintenance.
7		Appears when the “Boost/Purge preset”, or “Manual bypass mode” timer is active.
8		Appears when the “holiday mode” is enabled.
9		Appears when performing anti-frost to protect the Heat Exchanger, by adjusting air volumes or operating a pre-heater.
10		Appears when the “Silent mode” is active.
11		This is displayed while linking with an air conditioner.
12		This is displayed when the Fan speed is fixed by an external input.
13	Outdoor, Return, Supply temperature	The outside air temperature, return air (extract) temperature, and supply air temperature are displayed.

Fan Speed Operation



Press the **F2** button to change the fan speed in the following order:

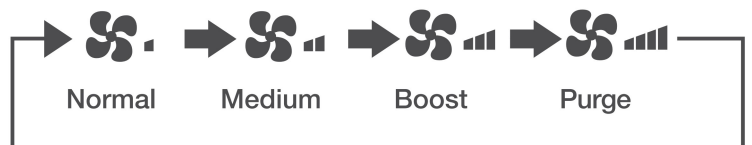

Some speeds will be hidden if uncommissioned. In some instances, only 1 speed will be available.

Ventilation Mode

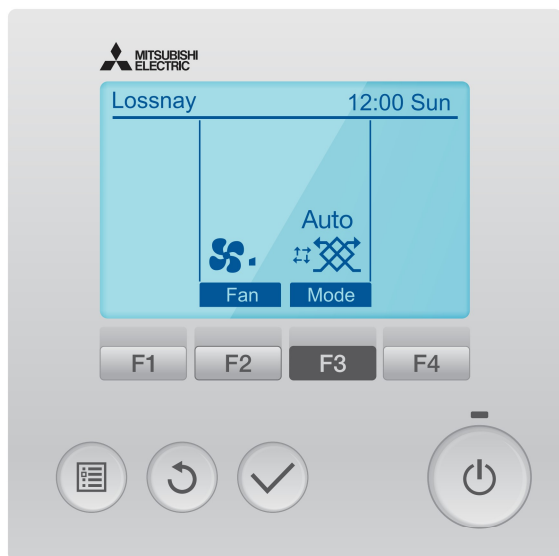

Press the **F3** button to go through the ventilation modes in the following order:

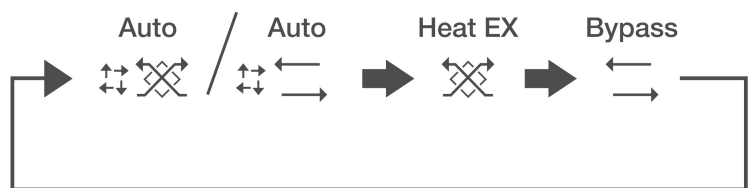

Bypass mode may only be available through the user options > Manual Bypass mode menu.

It is advised to leave the unit in Auto mode.

Icon	Function
Auto / Auto 	It automatically switches between heat exchange mode and bypass mode by temperature detection.
Heat EX 	Heat exchange mode.
Bypass 	Bypass mode.

Clock Setting

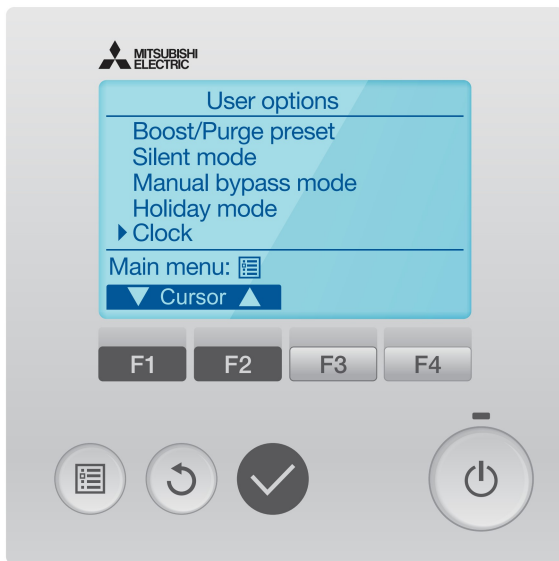

Step 1

Select «**User options**» from the «**Main menu**» screen and press the  button.

Select "**Clock**" and press the  button.

Clock setting is required before making the following settings.

- **Boost/Purge present**
- **Silent mode**
- **Manual bypass mode**
- **Holiday mode**





Step 2

Increase or decrease the value, and press the  button.

A confirmation screen will appear.

Navigating through the screens.

- To go back to the «**Main menu**» screen press 
- To return to the previous screen press 

Silent Mode

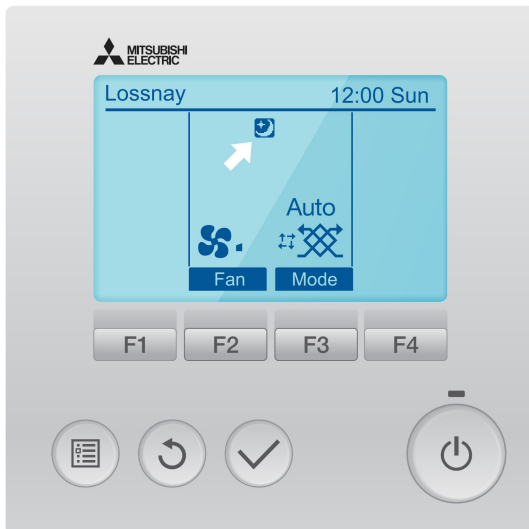

Silent mode is an effective mode for noise prevention at night. During Silent mode, icon will appear on the «**Main Display**» screen.

Under Silent mode, the signal from the external input and are not received.

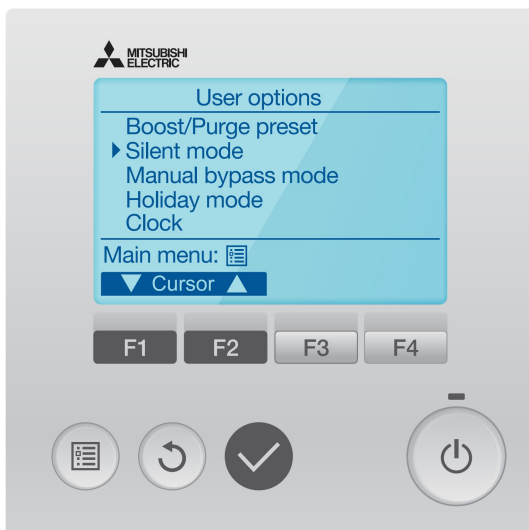

Step 1

Select “**Silent mode**” from «**User options**» screen, and press the  button.



Step 2

Mode set: Select “**No**” or “**Yes**”.

Factory default setting is “**No**”.

Mode set: “**Yes**”, You can set day.

Mode set: “**On/Off**”, You can set the time during day.

Holiday Mode

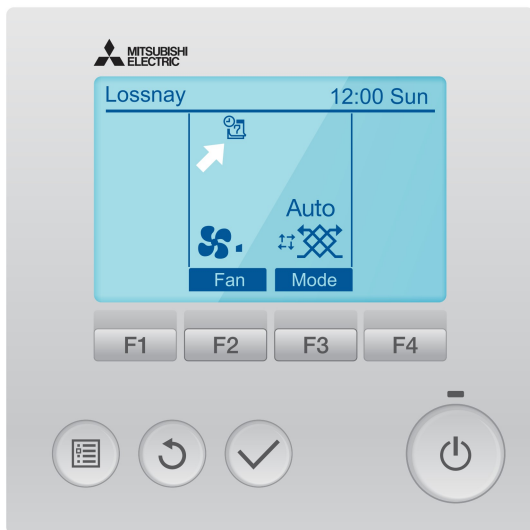

Holiday mode is used when you are away from home. When in holiday mode, the unit will operate at 50% of the lowest commissioned speed.

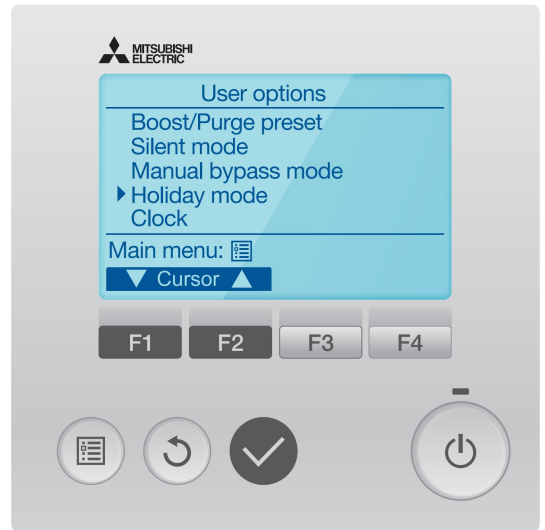

Step 1

Select Holiday mode from «User options» screen, and press the  button.

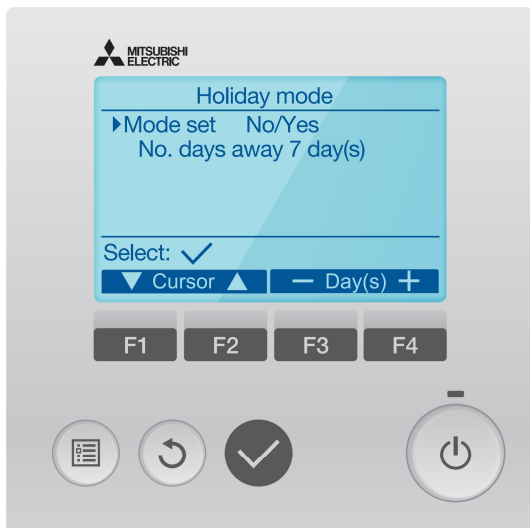

Step 2

Mode set: Select “Yes” / “No”.

You can set amount of days that you will not be in the house, 1-90 day(s).

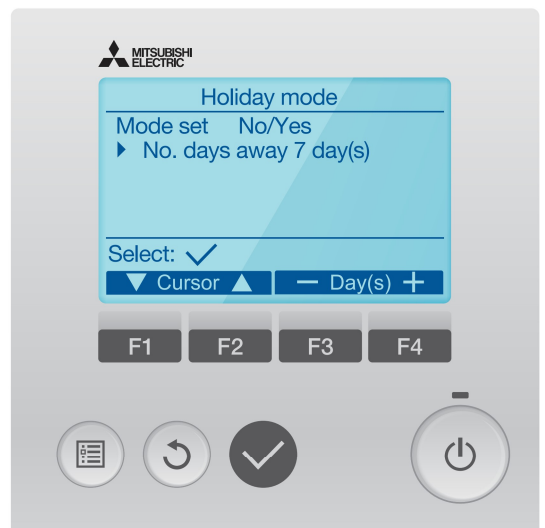

After pressing  Holiday mode starts.

Filter Information



When this sign  appears, clean or replace the filters.



Step 1

Select Maintenance from «Main menu» screen, and press the  button.

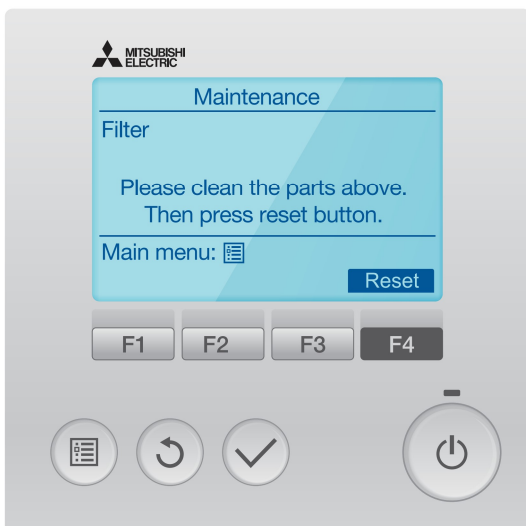

Step 2

Press the **F4** button to reset cleaning sign.

Refer to 'Care of Filers' section for information to clean the filters.

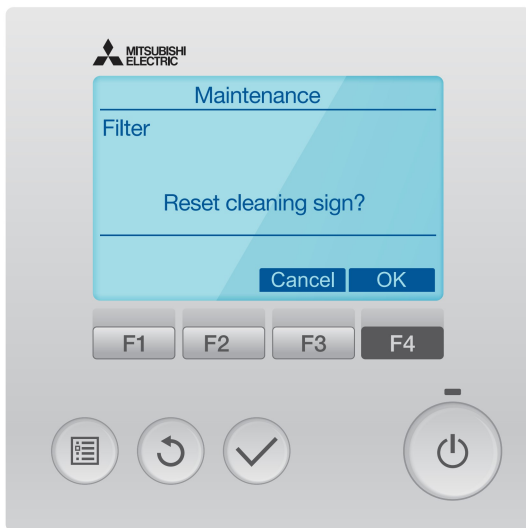

Step 3

Select “OK” with the **F4** button.

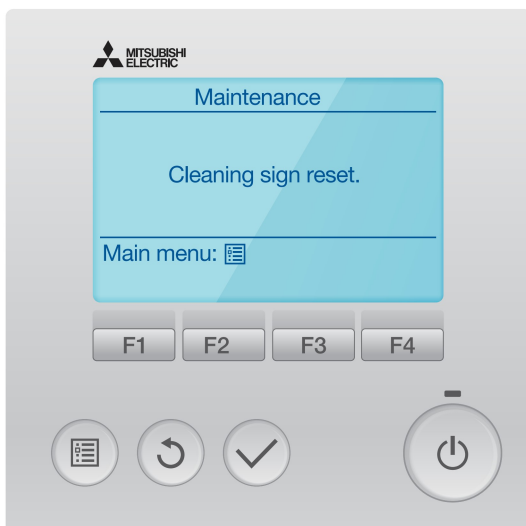

A confirmation screen will appear.

On/Off Control

By default, this button is disabled as it is a continuous ventilation system.

If available, press the  button.

The ON/OFF lamp will light up in green, and the operation will start.

Press the  button again.

The ON/OFF lamp will go out, and the operation will stop.

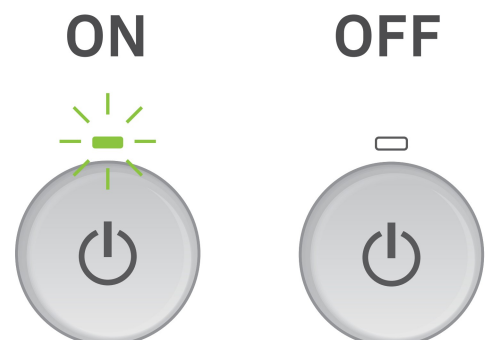

Error Information

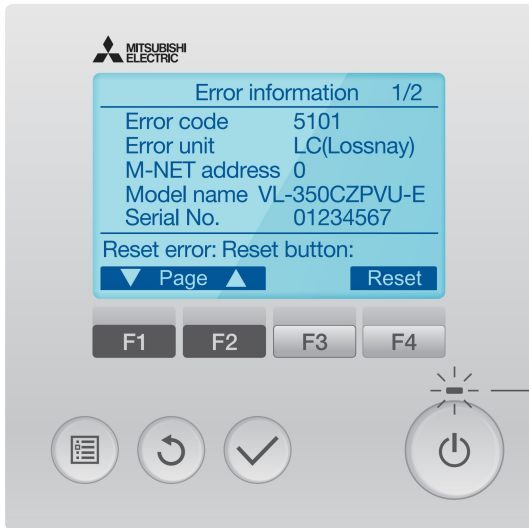

When an error occurs, the following screen will appear. Check the error status, stop the product, and consult a ventilation installation engineer.

Error code, error unit, unit model name, and serial number will appear.

The model name and serial number will appear only if the information have been registered.

Press the **F1** or **F2** button to go to the next screen.

Blinks

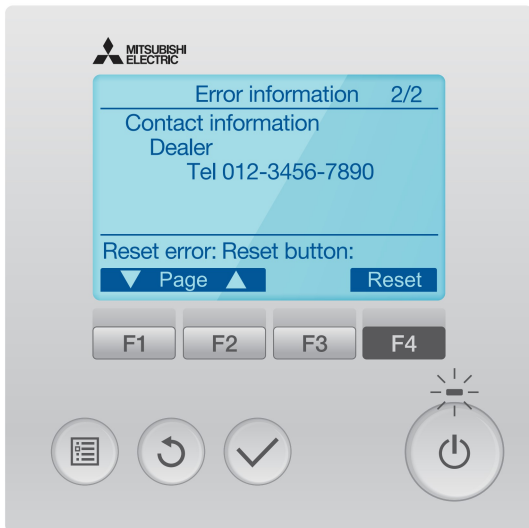

Contact information (dealer's phone number) will appear if the information has been registered.

Press the **F4** button to reset the error information.

Care of Filters

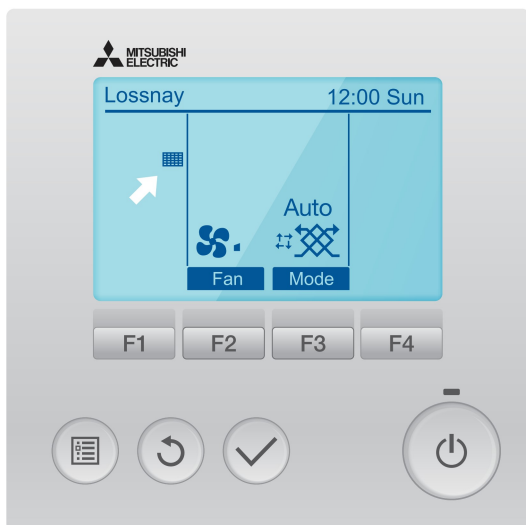

Remove dust and dirt on air filters at regular intervals in order to prevent a deterioration in the functions. Clean it at least once every 6 months.

 will appear on the «Main Display» screen when the filter needs to be cleaned.

Default setting is 6 months.



Special filters such as PM2.5 and NOx filters cannot be replaced.

Details of fitted filter  and intervals can be found in the commissioning log at the back of this document.



WARNING

Be sure to turn off the circuit breaker on the power board before cleaning and maintenance. Failure to heed this warning may result in electric shock or injury.



CAUTION

Wear gloves during cleaning and maintenance. Failure to wear gloves may result in injury. During cleaning and maintenance, do not climb on an unstable stand. Injury may result if you tumble down.

Step 1

Turn off the isolater on the power board before removing filters.

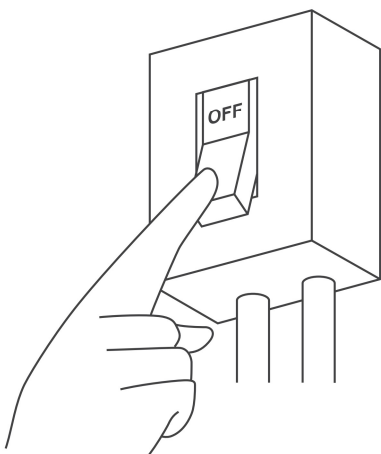

Step 1

Remove the **filter covers** (outside air filter and exhaust air filter).

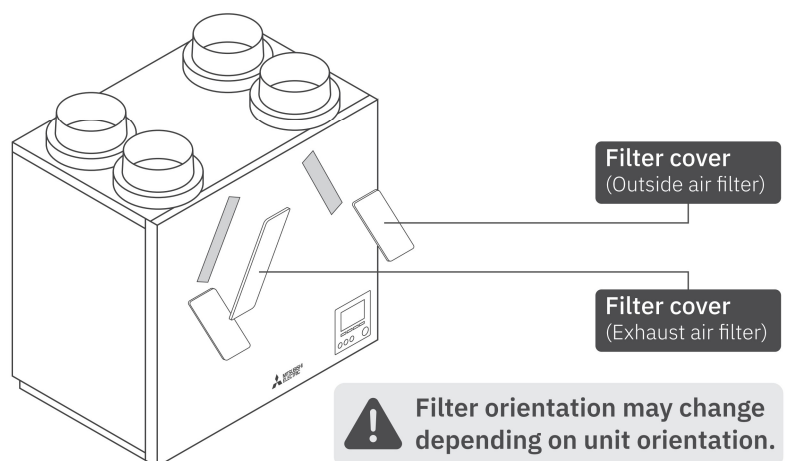

 Filter orientation may change depending on unit orientation.

Care of Filters

Step 3

Gently draw out the **filter cases** (outside air filter and exhaust air filter).

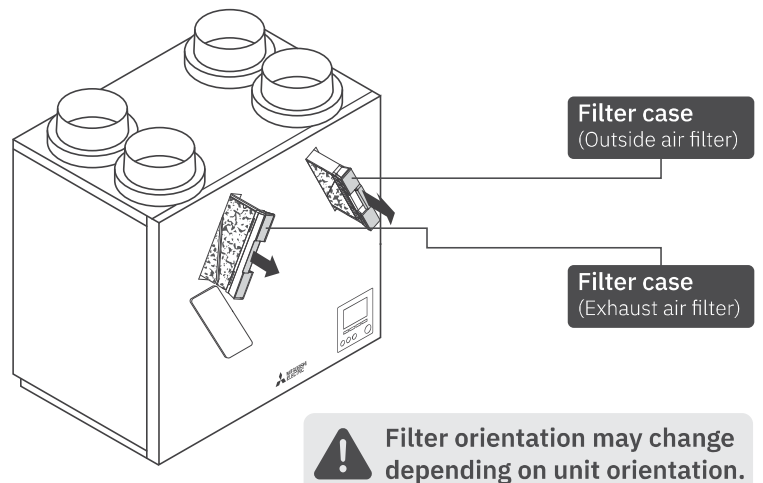

! Ensure that filter types do not change location as this can change and unbalance the air flow.

! Filter orientation may change depending on unit orientation.



CAUTION

When removing the outside air filter case and exhaust filter case, dew condensation water that has built up inside sometimes drips. So, remove the filter cases gently by supporting them with both hands so that they are not tilted.

Step 4

Remove the air filters from the outside air filter case and the exhaust air filter case.

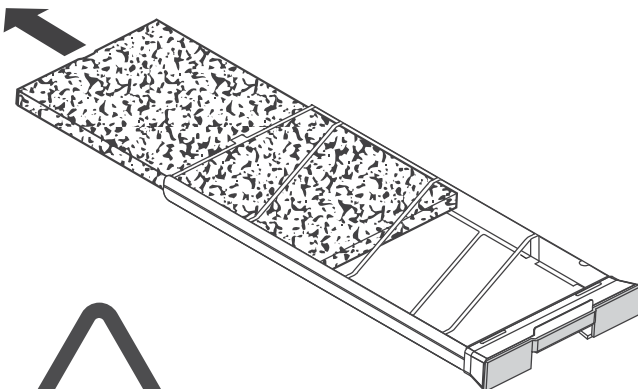

When the filter is heavily soiled, press and wash the filter with cold or warm water (40°C or less), and then air-dry the filter.

Do not wash the filter as shown opposite, otherwise it can be distorted.

Do not wash the filter with hot water.

Do not wash the filter by rubbing or scrubbing.

Do not squeeze or twist the filter.

Step 5

Remove the dust with a vacuum cleaner.



Further Information

Further information is available on the **Mitsubishi Electric Document Library**. Please use the web addresses or scan the QR codes below.

1. Register the homeowner guarantee

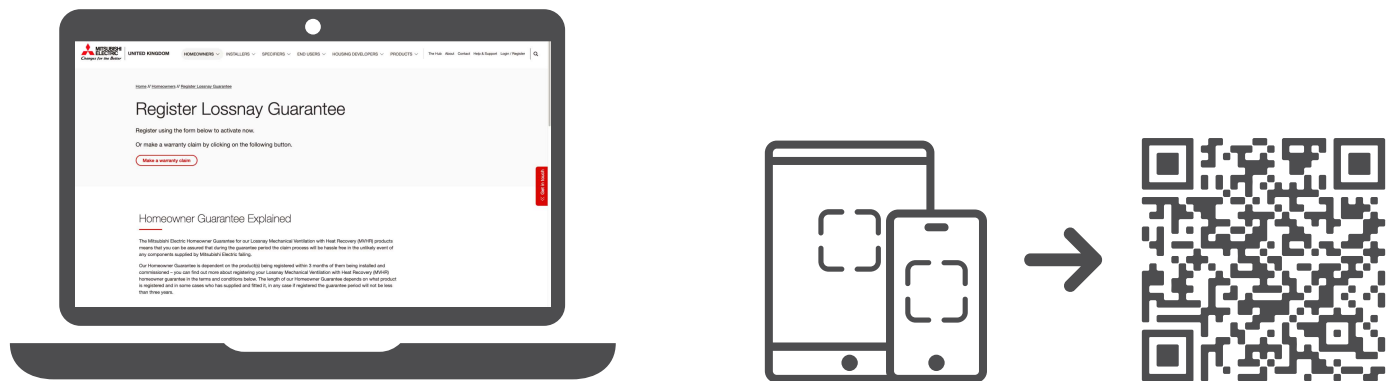

les.mitsubishielectric.co.uk/homeowners/register-lossnay-guarantee

2. Instruction Manual



library.mitsubishielectric.co.uk/pdf/book/VL-250-350CZPVU-E_Instruction_Manual__876H46401#page-1

Troubleshooting

Take the following actions if trouble shown in the table below occurs.

If trouble is not corrected even after taking the required action, or if trouble other than that indicated in the following table occurs, **turn OFF the isolator**, and then contact a ventilation installation engineer or an electrical engineer.

Symptom	Cause	Action
No Operation	Power is not supplied to the product.	Check the circuit breaker on the power board.
	The ON/OFF button on the controller is not “ON”.	Press the ON/OFF button on the controller to turn on.
Operating noise has increased	The filter is not installed securely.	Re-install the filter.
	The filter is clogged.	Clean the filter.
	The outdoor hood is blocked.	Remove obstacles.
Air flow has reduced	The filter is clogged.	Clean the filter.
Burbling noise from product	Dew condensation water in the drain pipes is sucked into the wind taken in by the product but is not being discharged.	Reduce the fan speed of the ventilation unit. The noise will disappear as it becomes easier to discharge the dew condensation water in the drain pipes.
Noise fluctuates	Noise sometimes gets louder because of the influence of outside wind. This is not a malfunction.	If you are worried about sound fluctuation, contact your ventilation or an electrical engineer.
Dew condensation water in the filter case	Dew condensation water sometimes builds up in some operating environments.	It is not a malfunction.
The volume of the operating noise is different in different rooms	The volume of the noise sometimes differs, for example, because of the length of the piping to each room.	It is not a malfunction.
During winter season, Sometimes supply air stops.	The unit is operating in the supply air intermittent mode to prevent the heat exchanger becoming frozen.	It is not a malfunction. See “Automatic supply air stop function/Automatic supply air intermittent operation function.”

Symptom	Cause	Action
Inside the product or the filters are wet.	Inside the product or the filters can become wet due to fog outside or condensation.	It is not a malfunction.
The air volume increases/ decreases without any command.	The air volume can increase/ decrease automatically if the product receives external output.	It is not a malfunction. Check the setting.

Controller

Symptom	Cause	Action
The air volume is changed without any command.	To protect the Heat exchanger from frost in winter, the air volume can increase/decrease. The air volume can increase decrease automatically if the product receives external output.	It is not a malfunction.
The air volume is not changed even when the product fan speed is changed.	When receiving the external input, the priority is given to it even when the lower fan speed is selected. (External input icon is displayed if the fan speed is determined by the external input.)	It is not a malfunction.

Commissioning Checklist

This commissioning checklist is to be completed in full by the installer who commissioned the Lossnay and associated equipment as a means of demonstrating compliance with the appropriate regulations and then handed to the customer to keep for future reference.

For further information to install, please refer to Mitsubishi Electric training literature and installation manual.

Failure to install and commission this equipment to the manufactures instructions may invalidate the warranty but does not effect statutory rights.

Customer Information

Name:

Address:

Telephone:

Email:

Installer Information

Name:

Address:

Company:

Telephone:

Email:

ME Installer No.

Building Information

Continuous ventilation / extract low rate (Part F 2010, table 5.1b) (l/s)

Boost extract minimum high rate (Part F 2010, table 5.1a) (l/s)

Building Regulations Notification No.

Speed Information

Normal: Supply % Extract %

Medium: Supply % Extract %

Boost: Supply % Extract %

Purge: Supply % Extract %

Boost Control(s) Information (Please tick the appropriate box)

Dedicated switches

Interlocked light switches

Automatic sensors

Other, please state:

Delay timer (min):

Overrun timer (min):

Automatic Bypass Information

Desired indoor temperature (°C):

Minimal external temperature (°C):

Temperature difference (°C):

Filter Maintenance Information (Please tick the appropriate box)

Outside air: Standard G3 (default) PM2.5

Return air: Standard G3 (default)

Supply air: PM2.5 NOx

Outside air filter intervals: Clean every months / Replace every months

Return air filter intervals: Clean every months / Replace every months

Supply air filter interval: Replace every months

Note: Default intervals for standard filters is to clean every 6 months and replacement after 12 months. Default intervals for PM2.5 and NOx filters is replacement every 6 months, unless the PM2.5 filter is fitted in the supply air alongside a standard filter for the outside air in which case the default interval is to replace every 12 months.



Telephone: **01707 282880**
email: air.conditioning@meuk.mee.com
les.mitsubishielectric.co.uk

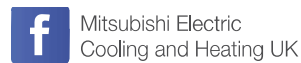

UNITED KINGDOM Mitsubishi Electric Europe Living Environmental Systems Division,
Travellers Lane, Hatfield, Hertfordshire, AL10 8XB, England. Telephone: 01707 282880 Fax: 01707 278881
IRELAND Mitsubishi Electric Europe, Westgate Business Park, Ballymount, Dublin 24, Ireland.
Telephone: (01) 419 8800 Fax: (01) 419 8890 International code: (003531)

Country of origin: United Kingdom - Japan - Thailand - Malaysia. ©Mitsubishi Electric Europe 2021. Mitsubishi and Mitsubishi Electric are trademarks of Mitsubishi Electric Europe B.V. The company reserves the right to make any variation in technical specification to the equipment described, or to withdraw or replace products without prior notification or public announcement. Mitsubishi Electric is constantly developing and improving its products. All descriptions, illustrations, drawings and specifications in this publication present only general particulars and shall not form part of any contract. All goods are supplied subject to the Company's General Conditions of Sale, a copy of which is available on request. Third-party product and brand names may be trademarks or registered trademarks of their respective owners.

Note: The fuse rating is for guidance only. Please refer to the relevant databook for detailed specification. It is the responsibility of a qualified electrician/electrical engineer to select the correct cable size and fuse rating based on current regulation and site specific conditions. Mitsubishi Electric's air conditioning equipment and heat pump systems contain a fluorinated greenhouse gas, R410A (GWP:2088), R32 (GWP:675), R407C (GWP:1774), R134a (GWP:1430), R513A (GWP:631), R454B (GWP:466), R1234ze (GWP:7) or R1234yf (GWP:4). *These GWP values are based on Regulation (EU) No 517/2014 from IPCC 4th edition. In case of Regulation (EU) No.626/2011 from IPCC 3rd edition, these are as follows. R410A (GWP:1975), R32 (GWP:550), R407C (GWP:1650) or R134a (GWP:1300).

